

2R100ER

Trituratori industriali
Industrial shredders



2 alberi / Azionamento elettrico

2 shaft / Electric drive

75 kW

2R100ER

Made in Italy 

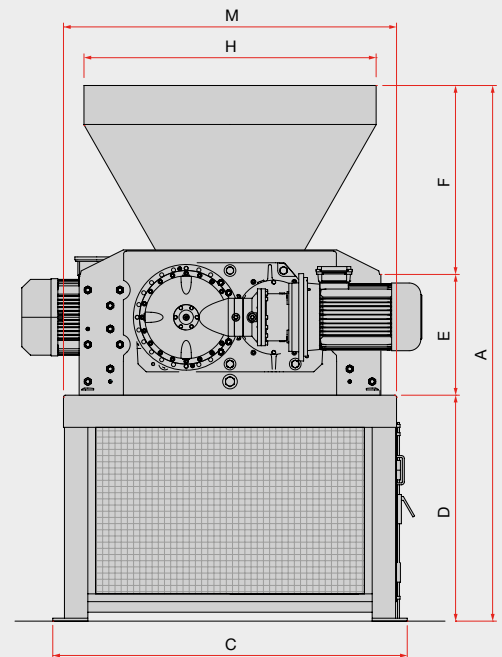
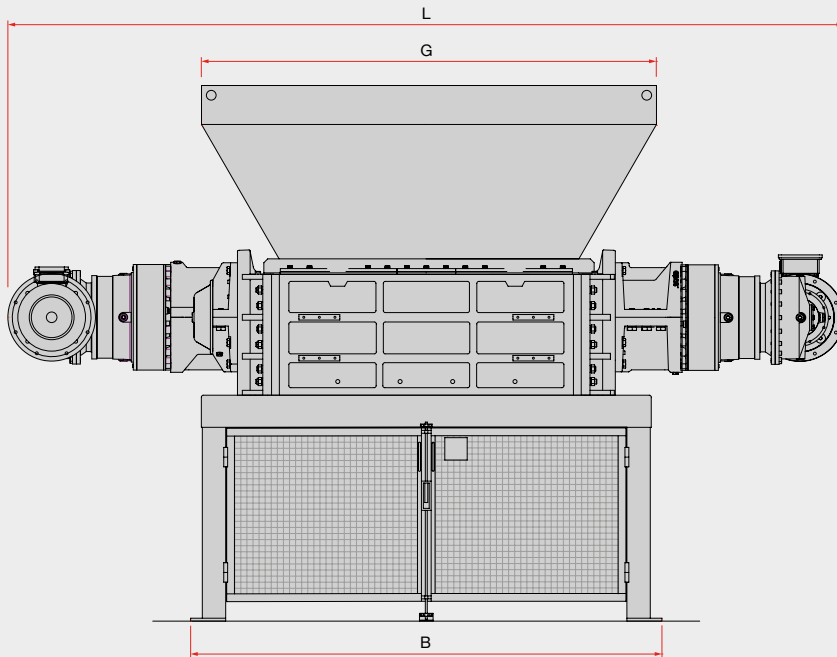





Dimensioni - Dimensions

Modello Model	A mm	B mm	C mm	D mm	E mm	F mm	G mm	H mm	L mm	M mm
2R15/100ER	2750	2420	1820	1160	620	970	2340	1500	4295	1710
2R20/100ER	2750	2870	1820	1160	620	970	2790	1500	4745	1710

Dati tecnici - Technical data

Modello Model	Camera di lavoro Shredding chamber	Spessore lame Blades thickness	Potenza Power	Peso Weight
2R15/100ER	1510x1100 mm	50 - 75 mm	75 (45+30) kW	11950 kg
2R20/100ER	1960x1100 mm	50 - 75 mm	75 (45+30) kW	14150 kg

Applicazioni - Applications

	Plastica Plastics	3-5
	Fusti di plastica (200-220 L) Plastic drums (200-220 L)	80-130 pcs/h
	Rifiuti solidi urbani Municipal solid waste	5-10
	Fusti di metallo Metal drums	80-130 pcs/h
	Filtri olio Oil filters	2-3
Materiale - Material		t/h