

## F 410/360/RI

Caractéristiques Technical data	F410/360/RI
Chambre de broyage (mm) Shredding chamber (mm)	368x500
Lames (nombre et épaisseur) Blades (number and thickness)	à définir selon la solution attendue to be agreed according to the specifics required
∅ matière sortante - broyat (mm) ∅ material output (mm)	6÷12
Puissance électrique (kW) Power (kW)	7,5
Tension (V) Voltage (V)	220/400/460

# Documentation Technique / Technical Data

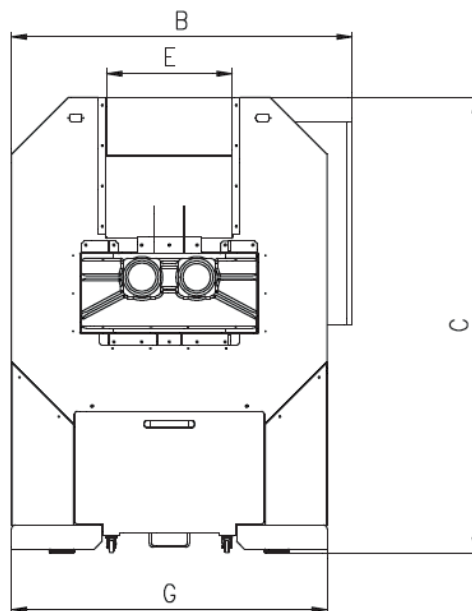
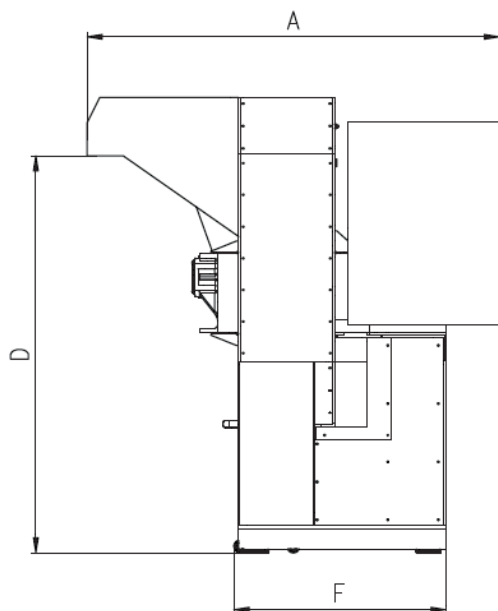

## Déchets traités / Some applications:

Disques durs  
Hard discs



40÷60 pcs/h  
40÷60 pcs/h

## F410/360/RI

A	1630
B	1350
C	1800
D	1570
E	495
F	840
G	1250

CAT1028 Rev. 0 04/15

### SatrindTech S.r.l.

Via Monfalcone, 122 - 20010, Arluno (MI) - Italie  
Tel. (+39) 02 90 37 66 83

sales@satrindtech.com  
satrindtech.com

### SatrindTech France - Groupe SEREX

19, chemin de la Violette, 31240 L'Union - France  
Tel. (+33) 05 62 89 08 88

contact@satrindtech-france.fr  
www.satrindtech-france.fr

