

F 410/360
F 410/420
F 410/480

Caractéristiques Technical data	F410/360	F410/420	F410/480
Chambre de broyage (mm) Shredding chamber (mm)	368x500	428x500	488x500
Lames de 15 mm (u) 15 mm blades (no.)	24	28	32
Lames de 30 mm (u) 30 mm blades (no.)	12	14	16
Puissance électrique (kW) Power (kW)	7,5	7,5	7,5
Tension (V) Voltage (V)	220/400/460	220/400/460	220/400/460
Poids (kg) Weight (kg)	835	940	995

Documentation Technique / Technical Data

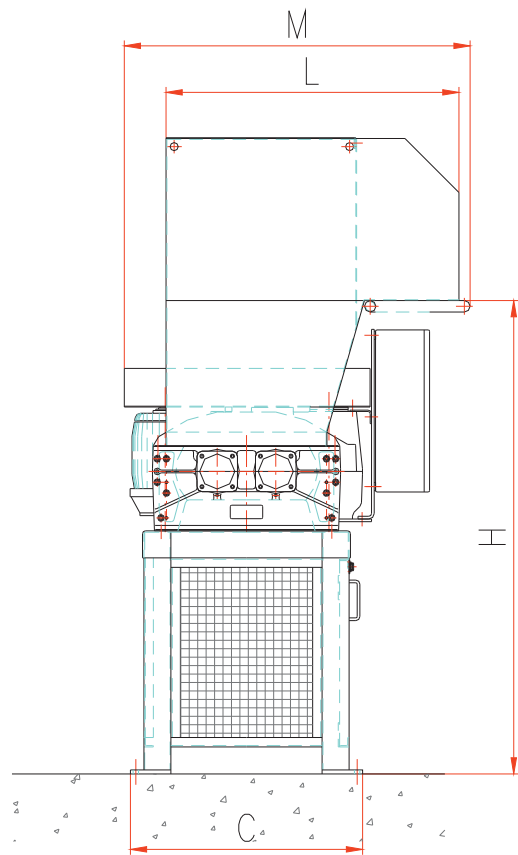
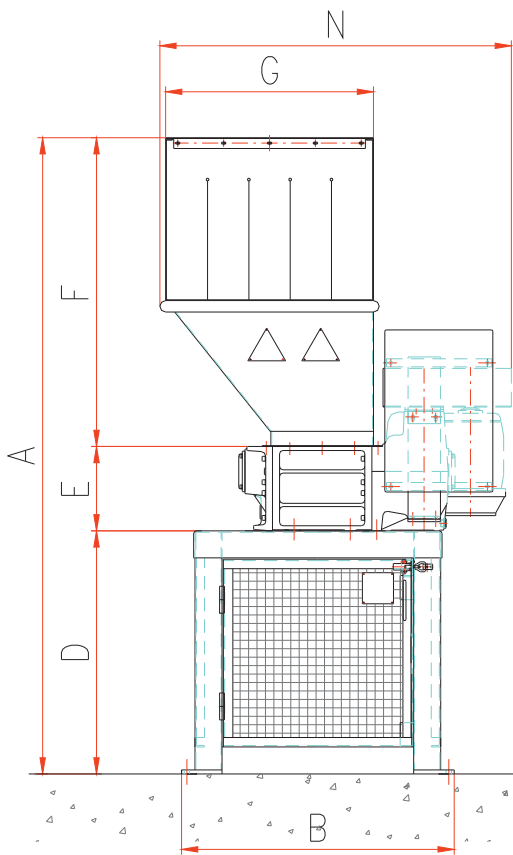

Déchets traités / Some applications:

Plastiques
Plastics



150 ÷ 300 Kg/h

Déchets hospitaliers
Hospital waste



100 ÷ 300 Kg/h

Déchets alimentaires
Catering waste



100 ÷ 300 Kg/h

Déchets industriels
Industrial scraps



100 ÷ 200 Kg/h

	F410/360	F410/420	F410/480
A	2355	2355	2355
B	1010	1010	1010
C	860	860	860
D	900	900	900
E	315	315	315
F	1140	1140	1140
G	770	770	770
H	1755	1755	1755
L	1085	1085	1085
M	1280	1280	1280
N	1300	1300	1300

CAT1006 Rev. A 04/15

SatrindTech S.r.l.

Via Monfalcone, 122 - 20010, Arluno (MI) - Italie
Tel. (+39) 02 90 37 66 83

sales@satrindtech.com
satrindtech.com

SatrindTech France - Groupe SEREX

19, chemin de la Violette, 31240 L'Union - France
Tel. (+33) 05 62 89 08 88

contact@satrindtech-france.fr
www.satrindtech-france.fr

